

Single Room Heat Recovery

MECHANICAL VENTILATION SOLUTIONS FOR RENOVATION OR NEW BUILD



IMPORTANT UPDATE TO PRODUCT INFORMATION

Due to product development, the diameter of the product has now changed from 180mm to 160mm.



COMMERCIAL



RESIDENTIAL



RMI



MORE THAN 60 YEARS OF EXPERIENCE

Founded in 1955, Airflow has grown from one man's expertise in fan design and air flow measurement into a thriving international group. Renowned for its innovative approach to new product development and air movement techniques, Airflow can offer you a variety of ventilation solutions to suit your needs.

With our headquarters in High Wycombe, Airflow has subsidiaries in Germany and the Czech Republic and has global distributors from Norway to New Zealand.

Listening to the requirements of our customer enables Airflow's knowledgeable and committed staff to continually develop new and innovative products that raise standards and provide long term, reliable ventilation solutions.



UNITED KINGDOM

High Wycombe (Head Office)

Our founder started the business in 1955, just one mile from the current site, which has been Airflow's headquarters since 1960, co-ordinating our global activities.



GERMANY

Airflow has been serving ventilation products and air measurement devices to the German and European markets for over 50 years. Operating near Cologne, Airflow Germany has their own customer service, sales and technical sales teams.



CZECH REPUBLIC

Founded in Prague over 20 years ago, the Airflow Czech Republic team offer sales and servicing of ventilation products for the Eastern European market.



BETTER VENTILATED HOMES MAKE BETTER LIVES

The requirement for many more affordable homes continues as does the need to improve the quality of the existing housing stock. The Decent Homes Programme has taken great strides in upgrading older dwellings but there is still much to be done.

As we build new and regenerate older dwellings to a higher standard of insulation, so we increase the conditions for dampness and mould growth and an environment with poor indoor air quality to thrive.

Where the UK Government support any retrofit works, it requires these to be done to Publicly Available Specification (PAS) standard. Such standards that exist are PAS 2030:2017, and the new PAS 2035 due out in mid-2019. These are available from BSI. The aim is that by ensuring these standards are followed and adhered to the quality of work improves.

A key element of PAS2035 is the requirement to install effective ventilation in all properties, especially those where insulation, or any other energy efficient measures are introduced.

Furthermore there is a requirement to check the ventilation in all properties and to upgrade the system when it fails to meet the specified criteria.

Therefore producing effective, efficient and compliant ventilation will be an obligation for social housing providers to combat the potentially harmful effects of dampness and mould and reduce the airborne pollutants which can result in a 'Toxic Home'.



UNDERSTANDING THE ISSUES

A highly respected report concluded that 40,000 deaths a year can be linked to air pollution.

Toxic Home Syndrome can develop Allergies,
Alzheimer's and strokes.

The health problems resulting from exposure to air pollution leads to premature death, a high cost to people who suffer from illness and to our health services and to business.

Source: The Royal College of Physicians: Every Breath We Take: the lifelong impact of air pollution April 2016

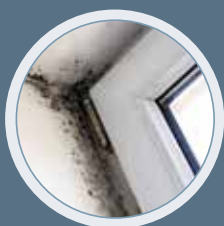

WHAT IS 'TOXIC HOME'?

If you live in an air tight home with poor air quality, you and your family can experience headaches, long lasting colds and bronchitis as well as chronic asthma and allergies.

15.3 million homes in the UK are at risk of Toxic Home Syndrome from the build-up of moisture and airborne pollutants, Volatile Organic Compounds (VOC's) within the air in your home.

Poor indoor air quality can lead to dampness and mould developing and damaging the fabric of the home and the air we breathe.



MECHANICAL EXTRACT VENTILATION WITH HEAT RECOVERY (MVHR)

Non ducted systems

This type of ventilation is where the existing air in the property is extracted, as it is extracted the heat is removed (recovered). Then the unit uses this heat to warm up the new fresh air entering the property. So giving you consistent fresh air that is warmed up using the recovered heat.

There are various solutions available:

Single room MVHR units, these are units that are installed in each room. They can be used in isolation in wet rooms (ensuite, bathrooms, utility and kitchens) or can be used in habitable

rooms (bedrooms, living rooms, dining rooms, home office). Factors that need to be considered when using these units is the amount of background ventilation available and that they need to go on an external wall.

You can also use single units as a total house solution, this is done by pairing units up and is very useful for where retrofit does not easily allow for a central MVHR unit to be installed.

Central room MVHR units, these are for the whole house solution where they supply and extract air for the whole dwelling using one central unit. With

central supply & extract you would need to use ducting to reach each of the rooms.

Airflow have central solutions where units can utilise space that is not always optimised, above a hob in the kitchen is such an area, we have combined a MVHR unit and an extractor hood together. This unit is ideal for apartments where storage space is of a premium. Another such space is above the front door, we have units that can be placed above the front door and the filters accessed from outside, so no need to disturb the occupants for any filter changes and maintenance.

Multi room extraction with Heat Recovery

Habitable room solution can also be combined to provide a total dwelling solution



Unohab

- Lots of flexibility and low noise levels
- EC Motors and built in filter
- Can be connected to other units to provide total house solution
- Systems can be designed to meet Part F
- Used in retro fit or new build
- Used in multiple occupancy properties
- Accessories that enable for the extract to be incorporated into properties with external wall insulation
- Suitable for various wall depths



Wet room solution that meets regulations



Unowet

- Ceramic heat recovery core
- Up to 88% heat recovery
- Ideal for use in wet rooms
- Meets building regulations for extraction System 1 with heat recovery
- Works in recovery mode or extraction only
- Built in filter
- Manual boost



Unohab VENTILATION SOLUTIONS FOR SINGLE HABITABLE ROOMS



Fresh air is needed to live a healthy life, lack of it has an impact on our general health and wellbeing. Ensuring a fresh, regular supply of air into the home has an impact on the home's energy consumption if the existing energy (heat) is not recovered. Extracting stale air from a home so that new air can enter the dwelling (through trickle vents in windows or naturally through gaps and cracks in the fabric of the building) normally means you will also lose the heat as part of the extraction. Central heat recovery systems (Airflow Adroit range) have been fitted as a way to overcome this, providing fresh incoming air that is heated up using the stale heated air that is leaving the building. It is now possible to also have this using a combination of non-central units, that do not need to have a ducted system associated with

them. This means they lend themselves to being used for the retrofit market as well as still being used for a total home solution when combined with multiple units.

New and renovated buildings are becoming more airtight due to insulation. The result: Natural air exchange can no longer take place in the rooms and the humid and used air is not discharged to the outside. In order to prevent moisture damage to the building structure (e.g. dampness and mould), the necessary air exchange rate must be continuous and automatic.

Airflow has developed different solutions depending on the application. The Unohab can be installed in any of the habitable rooms (bedrooms, living rooms, dining rooms, home office) and the Unowet can be installed in wet rooms (toilets, en-suites, bathrooms, utility, kitchen).

Where multiple units of the Unohab are installed they are linked with each other to ensure the supply and extract function are synchronised.

From the ventilation technology perspective, controlled domestic ventilation with heat recovery will fully ensure energy efficiency of the building. In this respect, a decentralised ventilation system with heat recovery offers major advantages, especially in renovation, as it is an economical and simple solution for single rooms. Several of the points described in the following sections should be considered within the framework of the planning for the optimal operation of the ventilation system.

THE Unohab FROM AIRFLOW

With regard to decentralised ventilation, the focus is on two main points: On one hand, high efficiency is a prerequisite for the economical operation of the units whilst on the other hand, the individual ventilation units must form a complete system in perfect co-ordination with each other.

The Airflow Unohab unit is among the best in its class in both categories. Thanks to the preconfigured design and the quick and simple installation, the Unohab provides an economical solution for the ventilation of single rooms. The perfect combination of ceramic heat accumulator, flow straighteners and an EC fan make the Unohab exceptionally efficient and quiet.

A minimum of two alternating units form a functioning ventilation system, whereby multiple Unohab units are installed depending on the air requirement of the dwelling. The intelligent control unit enables the optimal adjustment of individual volume flows – even with an odd number of devices. Furthermore, it is possible for the first time to implement combi-ventilation in combination with extract air solutions, such as the Airflow QuietAir.

Commissioning is made simple: Thanks to the clever software, the settings can be configured directly via a PC or laptop - quick and user friendly. Thus, there is only one thing for the residents to do: Relax, sit back and take a deep breath!

ENERGY EFFICIENT VENTILATION SYSTEM UP TO 88% RECOVERY



Your benefits:

- Compact dimensions for external wall installation with minimum space requirements.
- Economical EC fans for maximum energy efficiency.
- Heat recovery efficiency of up to 88%.
- Convenient control, can be connected to extractor fans for combined ventilation.
- Simple commissioning by connecting the controller to the PC or laptop.
- Multiple award-winning design, perfectly suitable for the Airflow extract fans from the QuietAir range.

The *Unohab* opens up completely new possibilities for the economical ventilation of single rooms. The *Unohab* is particularly useful if there is limited space available due to its compact dimensions, whether it is used in new construction or a renovation, for single-family houses or apartment buildings.

The heat recovery is regenerative with the help of a ceramic heat accumulator. During extract air operation, this absorbs and stores the heat from the indoor air in a ceramic accumulator, so that the recovered heat can be transferred to the incoming fresh air during the subsequent supply air phase.

The ceramic accumulator is dirt-repellent due to the smooth surface that ensures constant hygienic operation in connection with the protection grille and the integrated filter. For the sake of balanced ventilation, one functional system consists of a minimum of two units, which operate in their operating modes (supply air/extract air) in alternating phases. Furthermore, the total number of ventilation units depends on the air requirement of the dwelling. In this respect, the volume flows of the individual units are perfectly coordinated with each other by means of the central control unit.

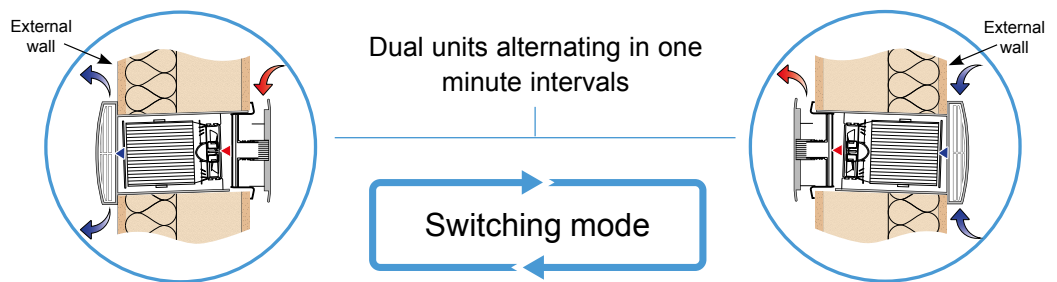

Extract air

During the extract air phase, the ceramic exchanger absorbs and stores the heat from the room air (storage charging).

Supply air

During the supply air phase, the fresh outside air absorbs the heat from the ceramic accumulator and this pre-heated air flows into the room.

With a balanced system, one unit brings in air from the outside, whilst the other extracts it.

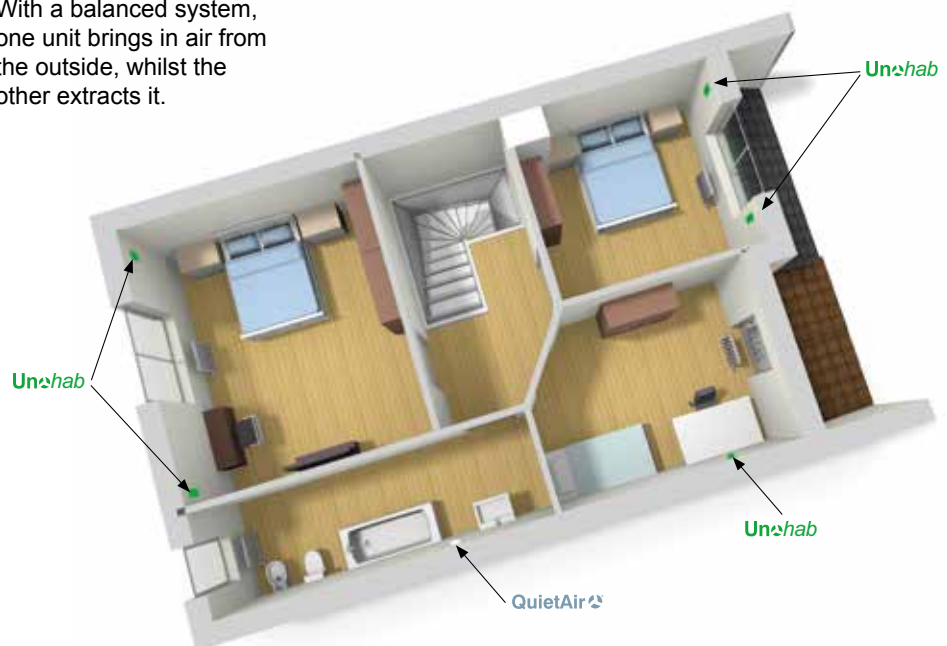

Unohab: AWARD-WINNING DESIGN



Features and benefits:

- Economical to operate with silent EC axial fan technology
- Elegant and unobtrusive design to blend with interior décor
- Flow rate up to 45 m³/h
- Up to 88% heat recovery efficiency
- Internal vent with efficient German design
- Easily installed with basic tools
- Very efficient core with flow straightening characteristics, culminating in high heat recovery and quiet operation
- Optional sound insulation elements to reduce the sound operation by maximum of 8 dB from the total sound pressure level
- ISO Coarse 50% (G3) air filter as standard, easily accessible which can be exchanged without tools
- Simple to adjust settings through its intuitive software
- LED display of current operating mode and fan speed
- Up to eight units may be controlled simultaneously
- Three operating modes (heat recovery, cross ventilation and supply air only)

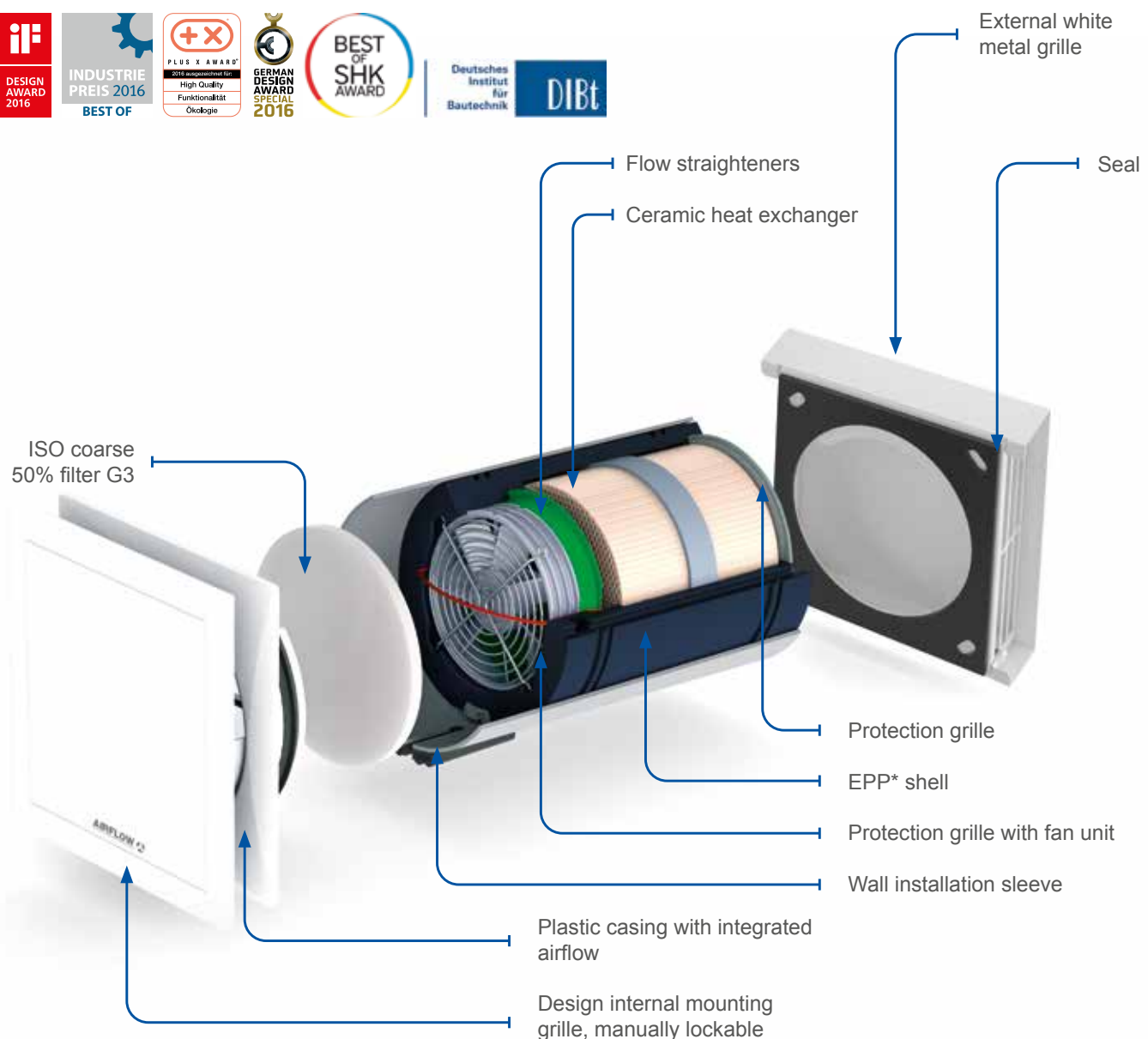

* Expanded Polypropylene

INTELLIGENT CONTROL



Controller Unohab

Clear display of the ventilation speeds and operating mode via the LED display. The functions can be selected using the buttons.

Ventilation Speed Button:
Three speeds + OFF

Operating Mode Button:

- Supply air mode
- Cross-ventilation mode (non-reversing mode)
- Reversing mode with heat recovery

Filter change display.

The reminder of the filter change interval is indicated by flashing LEDs depending upon the chosen interval time (3, 6, 9 or 12 months).



The Unohab is controlled intuitively via the LED controller, which can be used to control up to eight units at the same time. The buttons are used to select the three ventilation speeds and three operating modes (heat recovery, cross-ventilation

and supply air mode). The ventilation speed and operating mode settings can be seen immediately at any time with the dimmable LEDs. They also show the current status of the system and a pending filter change.

Unohab SOFTWARE - CONFIGURED, IN A FLASH.



Thanks to the software, the controller can be connected to a PC or laptop via the USB port. As an alternative to configuring the unit using the two buttons on the controller, the control unit can be accessed easily and conveniently in this way. Commissioning and the entry of necessary values (e.g. filter change intervals or

minimum ventilation stage) can be completed in a short space of time. All possible setting options can be changed quickly using the user interface and user-friendly support is provided with the corresponding help texts. The set configuration can be saved directly on the PC or laptop and re-programmed into the control unit if required. The installation cost in a larger property is thereby reduced to a minimum. If lots of the same ventilation systems are used, the configuration is just set once for a residential unit and can then be transferred to several controllers or apartments as required.

Mode 1 Green LED



Mode 2 Yellow LED



Mode 3 Blue LED



Mode 1– Reversing mode with heat recovery

The “reversing mode” function enables maximum heat recovery. In reversing mode, the Unohab units change between supply air and extract air mode. The ceramic heat accumulator integrated in the Unohab unit absorbs the heat from the passing air in extract air mode and transfers this heat into the incoming fresh air in supply air mode. Thus, up to 88% of the extract air heat is emitted into the incoming fresh air. The reversing mode (change of fan direction) activates every 60 seconds which permits the Unohab system to be at its highest efficiency and best performance.

Mode 2– Cross ventilation mode (non-reversing mode)

The “cross ventilation” function enables ventilation without heat recovery. For this purpose, the first Unohab unit, which is connected to the Unohab controller, is switched to supply air mode. The second Unohab unit, which is connected to the subsequent controller terminal, is switched to extract air mode. Cross ventilation function can also be defined as air

movement from one point of the property to another, resulting in cooling the inside air through a mechanical force that draws cool air in and pushes stagnant hot air outside.

Mode 3– Supply air mode

The “supply air mode” function enables the combination with an extract air fan (e.g. QuietAir). For this purpose, the Unohab unit, which is connected to terminal 10, is switched to supply air mode. As regards to the units connected to the subsequent controller terminal, they can also change to supply air mode or standby mode via the program mode.

All in all, the Unohab system has every option that a house needs for ventilation: heat recovery mode (warm up the indoor air), cross ventilation mode (cooling the air inside the house) and supply air mode in combination with extract fans (for a balanced ventilation in each room of the house). In addition, the Unohab system is small in size with an intuitive controller which makes it ideal for an apartment or a small house.

Unohab EXAMPLES



1 bed maisonette

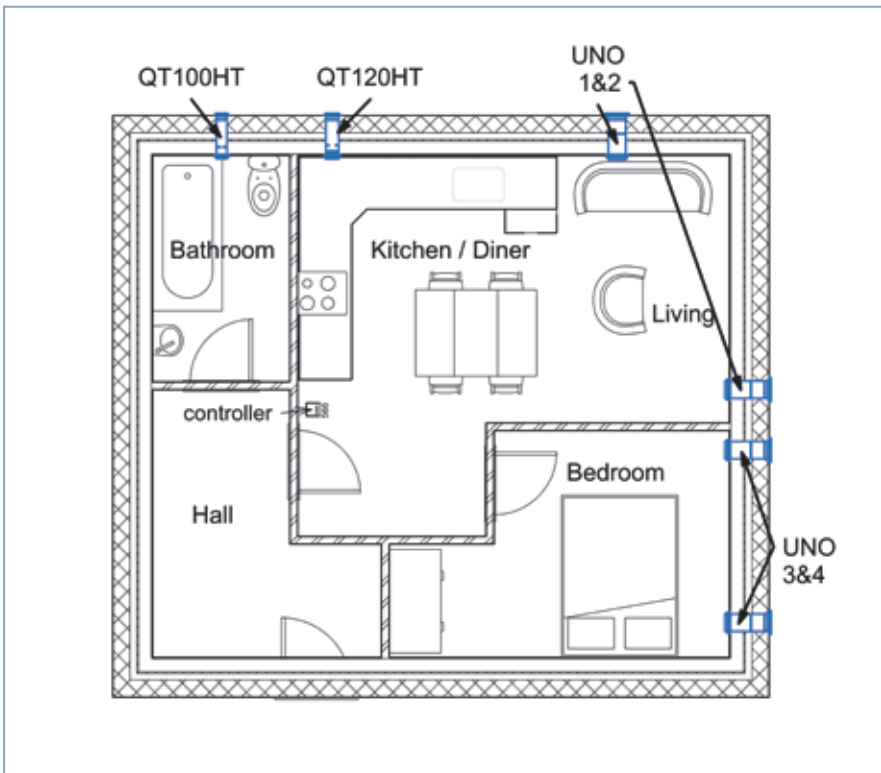

Two examples of where *Unohab* has been used to provide an MVHR solution to a total dwelling.

They have been combined with QuietAir extract fans to provide a complete ventilation system solution, so that the correct extraction rates are achieved to meet building regulations.

By using a control unit the *Unohab* units communicate with the QuietAir extractor fans. When the QuietAir is activated in the wetrooms, the *Unohab* switches to supply air only, ensuring there is enough replacement air entering the dwelling so the moist humid air can be removed.

KEY



Unohab



QuietAir

This is a representation of a 1-bedroom maisonette design. The number of units required is subject to the size of the dwelling.

1 BED MAISONETTE

The first example of installing the *Unohab* system is represented in a 1 bed maisonette as a whole house ventilation solution by being combined with QuietAir extract fans.

The following products have been used:

Part No.	Description	Location	Design
90001177	Unohab Cavity Wall Installation Kit	Kitchen / Dining-room Bedroom	2 pcs. in Kitchen / Dining-room 2 pcs. in Bedroom
90001179	Controller Flush Mounted Kit	Kitchen / Dining-room	1 pc. in Kitchen / Dining-room
9041261	QuietAir QT100HT	Bathroom	1 pc. in Bathroom
9041499	QuietAir QT120HT	Kitchen / Dining-room	1 pc. in Kitchen / Dining-room

Unohab EXAMPLES



2 bed maisonette

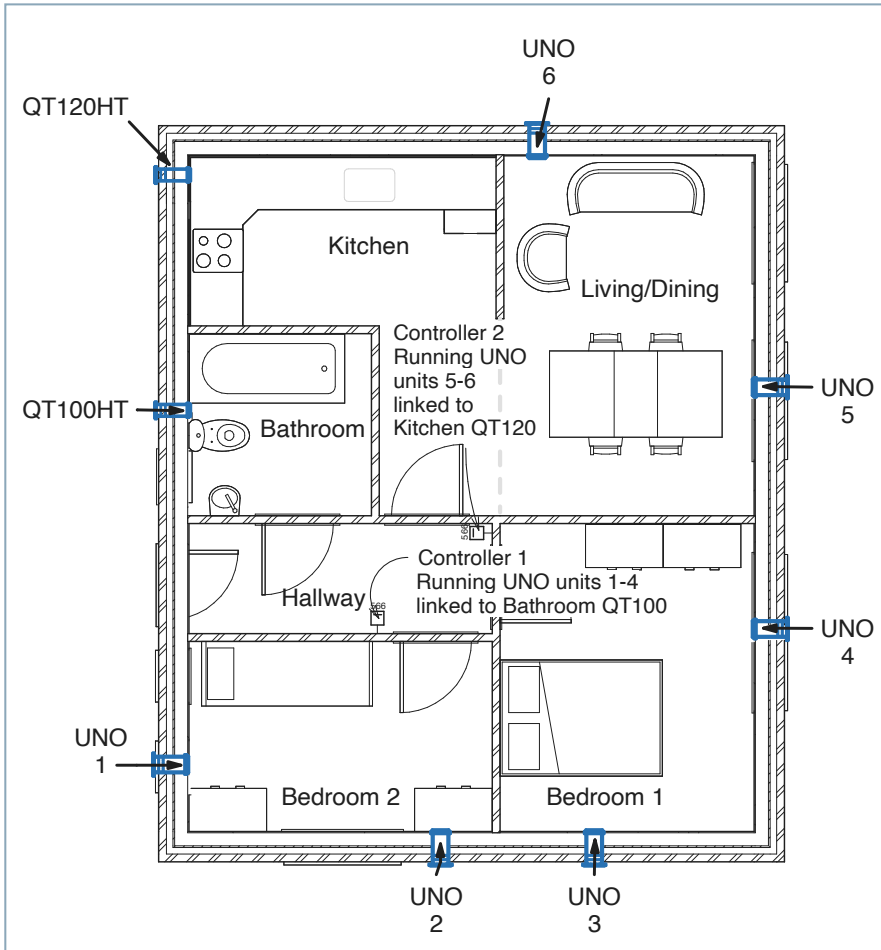

Example shown: 2 bed 48 m² Maisonette / Bungalow / Flat. Required trickle vent area 40000 mm² System 1 Extract rates; Bathroom 15 l/s, Kitchen 30 l/s.

Unohab units are set to speed 1 in bedrooms and set to speed 2 in living room.

All doors should maintain a minimum of 7600 mm² transfer air provision gap at the base.

This is a representation of a 2-bedroom maisonette design. The number of units required is subject to the size of the dwelling.

2 BED MAISONETTE

The second example of installing the Unohab system is represented by a 2 bed maisonette as a whole house ventilation solution by being combined with QuietAir extract fans.

The following products have been used:

Part No.	Description	Location	Design
90001177	Unohab Cavity Wall Installation Kit	Living / Dining-room Bedroom 1, Bedroom 2	2 pcs. in Living / Dining-room 2 pcs. in Bedroom 1 2 pcs. in Bedroom 2
90001180	Controller DIN Rail Mounted Kit	Hallway	1 pc. in Hallway / Controller 1
90001179	Controller Flush Mounted Kit	Living / Dining-room	1 pc. in Living / Dining-room / Controller 2
9041261	QuietAir QT100HT	Bathroom	1 pc. in Bathroom
9041499	QuietAir QT120HT	Kitchen / Dining-room	1 pc. in Kitchen / Dining-room

MEETING THE STANDARD



The *Unohab* is perfect for new build and renovation projects, with three operating modes and three ventilation speeds. The system can be paired with suitable extract fans to provide quiet, effective ventilation in any application.

The most common flow rate is 14 m³/h per unit for 5000 mm²

Equivalent Area at 1 Pa as tested according to BS 13141-1, Clause 4.

Taking this and Part F 2013 requirements into consideration for background ventilation, the *Unohab* system will provide sufficient supply in tandem with the intermittent fans operating in compliance with Approved

Document Part F.

Designed as a 'whole house' decentralised mechanical ventilation with heat recovery, the *Unohab* system enables balanced ventilation through a continuous alternating mode.

PRIMARY MECHANICAL SYSTEMS IN APPROVED DOCUMENT F1

The 2013 building Regulations, Approved Document Part F, means of ventilation prescribes minimum rates of ventilation within a dwelling. Compulsory for any project requiring planning consent and sign off by building control. It is of course good practise to follow regulations for any repair, maintenance and improvement work which impacts on the indoor environment.



The *Unohab* controller allows the resident to activate and deactivate heat recovery mode.

To ensure balanced ventilation, a minimum of two units are required for a small dwelling. Dependent upon the total air demand of the dwelling, more than two units can be installed in other rooms to provide complete 'whole house' ventilation.

The *Unohab* as a 'whole house' system is a hybrid of System 4. Backdraft flaps must be removed from the extract fans

and free area of the fans needs to be checked.

The innovative aspect of the *Unohab* system is that it provides System 1 and 3 compliant background ventilation, more thermally efficient (with heat recovery).

- Supplies & extracts air continuously at a low rate and incorporates a boost facility to extract pollutants and supply fresh outdoor air at a higher rate as required.

- Can be controlled either;
 - Manually boosted via multiple switches.
 - Automatically boosted, typically via humidity, CO₂, motion or other sensors.
- These should be clearly marked and located in an accessible location in or near the wet rooms.
- Replacement air is dealt with by balanced supply and extract.

THE QUIET PERFORMING EXTRACTOR FAN



QuietAir

For the first time, the operation of an extract air system (Airflow QuietAir range) can be intelligently combined with the Unohab units thanks to combined ventilation. The extension module Unohab EXM allows the combination of the two systems.

The Unohab operates in the habitable rooms and work in combination with the QuietAir extractor fans located in wet

rooms i.e: bathroom, en-suite, utility and kitchen.

Quietair fans are known for the highest pressure output, lowest sound levels and maximum energy efficiency. Two performance levels, jet water protection IP45 and high-quality long-life ball bearings are standard equipment features with clear added value. Quietair operates almost silently and consumes

around a third less energy than conventional extract fans.

The QuietAir range is available with overrun and interval operation or barrier-free automatic functions, such as presence detectors or humidity control. This reacts to humidity increases over time with intelligent electronics and effectively prevents mould formation.



QuietAir QT100



QuietAir QT120



QuietAir QT150

The Unohab ventilation system can be intelligently combined with a range of extract fans such as QuietAir by means of the Extractor fan module which electrically connects the two systems.

The QuietAir range offers very useful features including the innovative Room Refresh/ Interval Timer which can be used for programmable ventilation every 8, 12 or 24 hours. Another useful feature of the QuietAir is the optional Delay Start operation which avoids unnecessary use – ideal for those short visits during the night.

- Axial fan
- Two speed ventilation* up to 90m³/h (QT100), 170 m³/hr (QT120), 260 m³/h (QT150)
- Awarded Quiet Mark by Noise Abatement Society (QT100 / QT120 / QT150)
- Extremely quiet, noise levels as low as 25 dB(A)
- Power consumption from only 5 W
- Interval timer for routine auto extraction

According to Building Regulation Part F, a balanced ventilation Unohab system can be used with QuietAir QT100 which is perfect for the toilet, bathroom and en-suite and QuietAir QT120 which is suitable for the bathroom and utility room and the QuietAir QT150 is recommended for the kitchen.

The QuietAir fans can be operated by a range of control options including basic switching, timer, humidity and motion sensor control.

- Very low SFP from 0.09 W/l/s
- Long life ball-bearing motor 40,000 hours
- Integral flow straightener / backdraught shutter
- Powerful extraction for longer ducts
- Suitable for installation in Zone 1 of bathrooms when installed with an RCD
- IP45 rating
- Complies with Building Regulations
- 3 years warranty

*QuietAir range comes with various control options that activate the fan when needed - 2nd speed activated by remote switch.

Intelligent Humidity

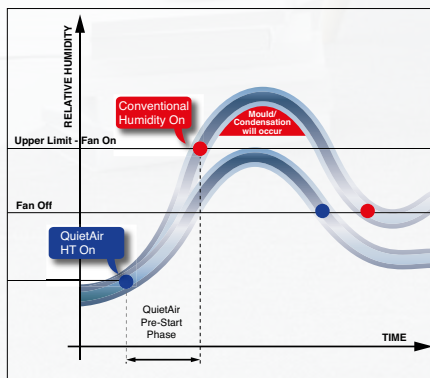

Airflow's intelligent humidity sensor offers the additional feature of being able to recognize a rapid increase in humidity and activates the boost speed before the pre-set value is reached so that preventive ventilation commences. Should this occur, the fan

switches off when the humidity level is within 10% of the set-point.

The benefits of this are that energy consumption is kept to a minimum and noise levels are reduced whilst ensuring optimum ventilation is achieved.

Specification	QT100B	QT100T	QT100HT	QT100MST	QT120B	QT120T	QT120HT	QT120MST	QT150B	QT150T	QT150 HT	QT150VS
Air flow m ³ /h	75 / 90				150 / 170				220 / 260			50 - 260
Air flow l/s	21 / 25				42 / 47				61 / 72			13 - 72
Fan type	Axial											
Controls	Basic	Timer	Humidity Timer	Motion Sensor Timer	Basic	Timer	Humidity Timer	Motion Sensor Timer	Basic	Timer	Humidity Timer	Variable Speed
Mounting	Wall / Ceiling											
Sound pressure dB(A)@3m	25 / 30				32 / 36				35 / 39			
Delay start	No	0, 45, 90, 120 sec's	0,2 mins	No	No	0, 45, 90, 120 sec's	0,2 mins	No	No	0, 45, 90, 120 sec's	0,2 mins	No
Adjustable timer (min)	No	6,10,15,21	6,10,15,21	15	No	6,10,15,21	6,10,15,21	15	-	6,10,15,21	6,10,15,21	-
Adjustable humidity (%RH)	-	-	60 - 90	-	-	-	60 - 90	-	-	-	60 - 90	-
Interval timer (hrs) optional	-	0, 8, 12, 24	-	-	-	0, 8, 12, 24	-	-	-	0, 8, 12, 24	-	-
Power watts	5 / 9				10 / 13				6 / 10			
Amps	0.04 / 0.06				0.08 / 0.09				0.07 / 0.12			
Building Regulations ADF	Yes											
Duct Diameter (mm)	100				125				150			
Voltage	230v / 1ph / 50 - 60 Hz											
Rating	IP45											
Max ambient temperature	40°C											
Weight (kg)	0.8				1.05				1.2			
Dimensions (H x W x D) mm	147 x 147 x 131				176 x 176 x 155				210 x 210 x 190			
Part No.	9041259	9041260	9041261	9041262	9041497	9041498	9041499	9041500	90000454	90000455	90000456	90000458

Performance

QuietAir QT100

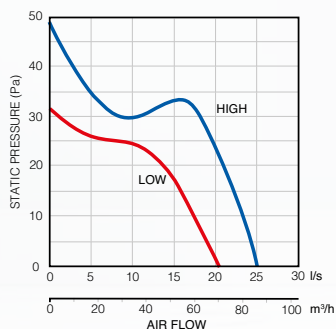

QuietAir QT120

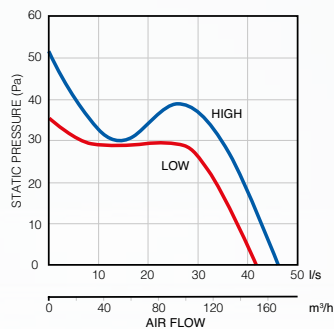

QuietAir QT150

..... Example performance of the QT150VS with variable speed control.

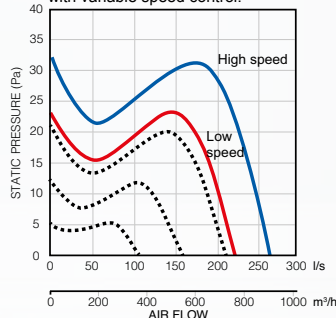

Dimensions (mm)

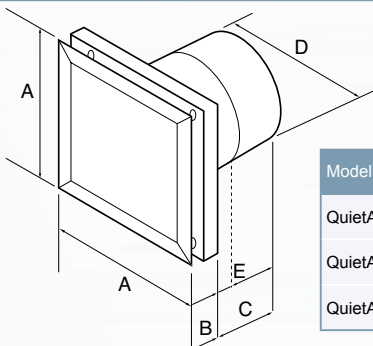

Model	A	B	C	D	E
QuietAir QT100	147	35	96	98	52
QuietAir QT120	176	39	116	118	70
QuietAir QT150	210	48	142	145	76

TECHNICAL DATA



The UnoHab unit functions are based on three fan speeds (low rate, average speed and boost). The fan performance graph shows maximum air flow against pressure combined with low noise level to deliver optimal ventilation.

The fan speeds can be controlled from the LED controller speed button being set on 'Away', 'Home' or 'Boost' mode.

1 Design-inner grille with filter

- White plastic design-inner grille with integrated air flow and ISO Coarse 50% (G3t) air filter.

2 Fan unit

- EC axial fan with 2-part connector
- EPP shell (base body)
- Ceramic heat accumulator
- Flow straightener
- Fan protection guard
- Pull-out cord
- Protection guard

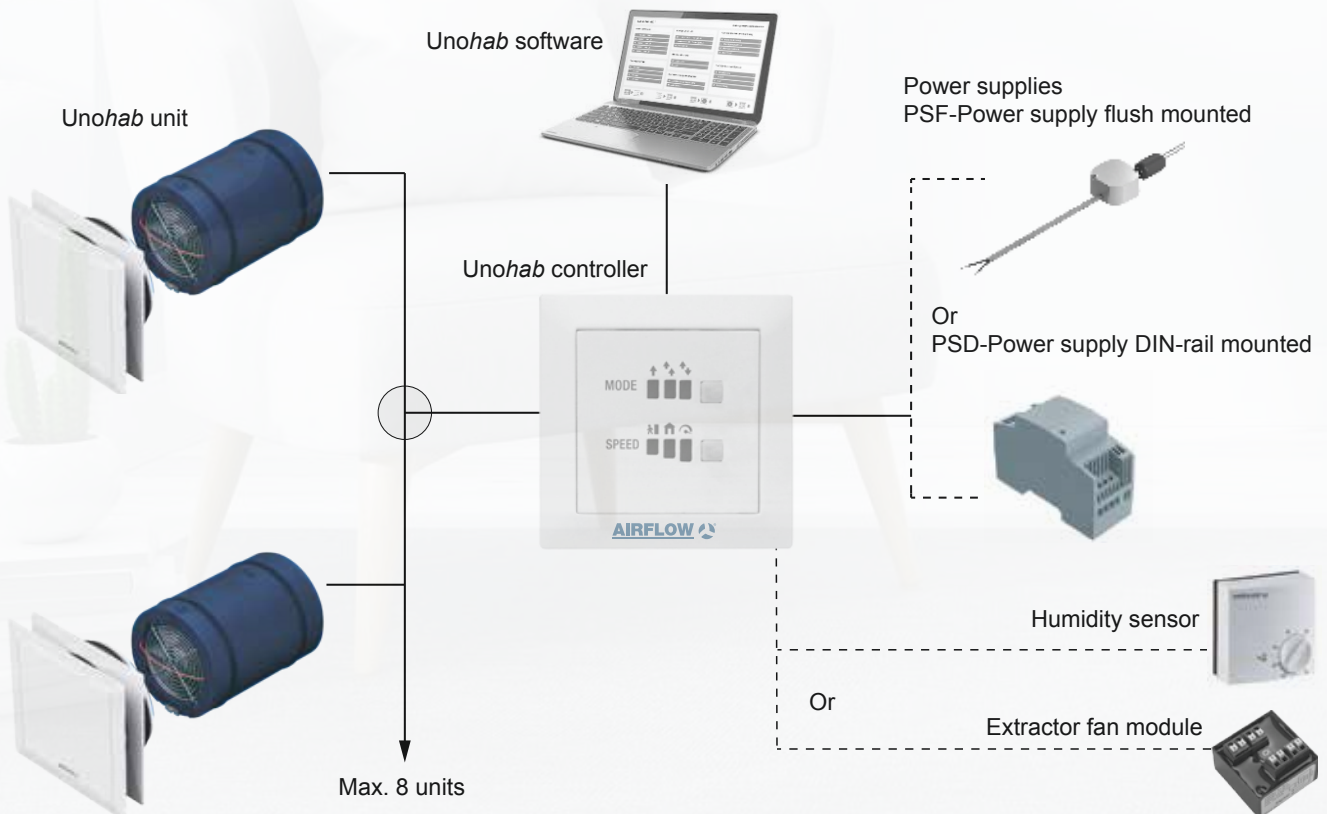

INSTALLATION METHODS



Installation in the facade

Unohab unit

- Minimum space required for installation within the cavity wall
- For retrofit and new dwellings
- Elegant German design for both internal and external grilles
- For wall thickness up to 800 mm
- Economical EC fans for maximum energy efficiency
- Heat recovery efficiency up to 88%
- Convenient control, can be connected to extract air fans for a hybrid whole system ventilation
- Easy to commission by connecting the controller to the PC or laptop
- Multiple award-winning design
- External white grille

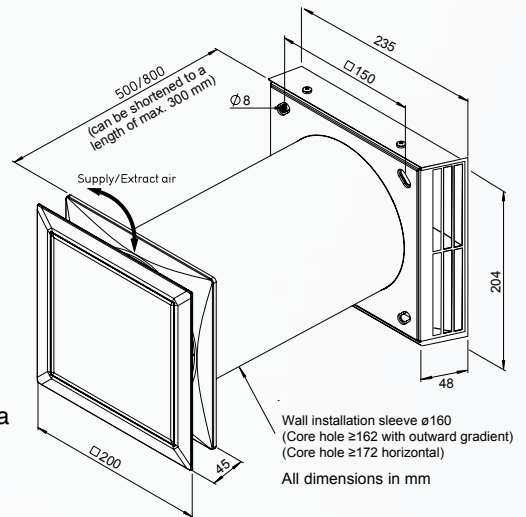

Installation in the window channel

External wall insulation vent kit

- No visible parts on the facade except for the wall grille
- Easy to incorporate in the thermal insulation layer
- For left or right side of the window installation with no modifications needed
- The wall sleeve length can be shortened as required
- Optional sound insulation elements can be integrated
- No special tools are required for installation
- Only four steps to follow for one Unohab unit to be installed in the window channel
- No components or external vents are visible on the external wall
- Insulation channel grille in stainless steel or white

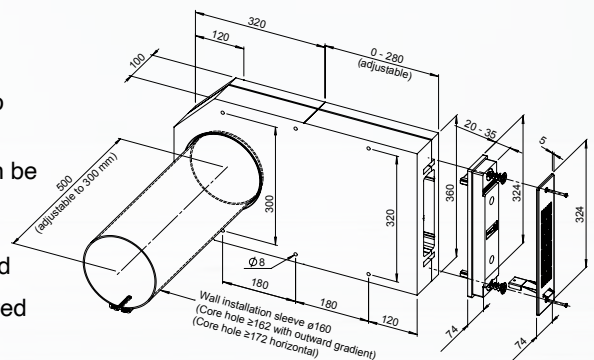

INSTALLATION



INSTALLATION IN THE FACADE

Depending on the fan unit option, wall cavities should be cut in advance, e.g. by means of core drilling, and the electrical wiring must be prepared for the installation of the Uno*hab* system. The fan unit can then be installed quick and easy in three steps:

Step 1

Install wall sleeve and external grille.

Once the wall installation sleeve has been fixed in the core hole, the external grille can be mounted to the finished facade.



Step 2

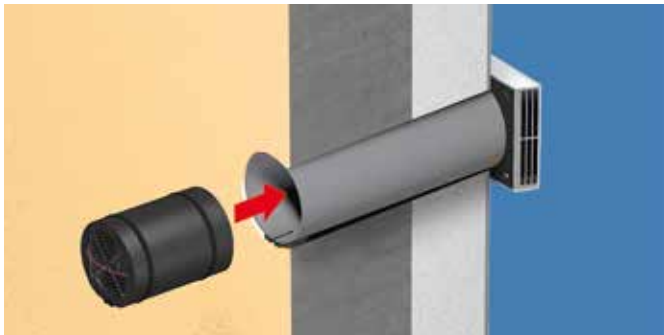

Insert unit and connect it electrically.

Once the construction or renovation measures are complete, the unit can be inserted in the wall sleeve and connected electrically. The fan unit is integrated in EPP shell, which ensures the thermal insulation of the external wall.

Step 3

Attach internal grille.

Once the fan unit has been installed, the internal grille with integrated filter can be attached. This can be performed effortlessly without any tools.



INSTALLATION



INSTALLATION IN THE WINDOW CHANNEL

The air inside a thermal insulation system is directed 90° in the window soffit with the newly developed soffit element made from highly insulating EPP. Apart from the grille in the window bar, no parts are visible on the external wall.

Step 1

Install wall sleeve and external wall insulation channel.

Once the wall installation sleeve has been fixed in the core hole, the external wall insulation channel can be installed on the outside.



Step 2



Attach external wall insulation channel.

The external wall insulation channel can be installed flexibly on the right or left, without conversion or additional costs. Furthermore, the EPP element can be shortened as required using a saw or hot wire. The external wall insulation channel is attached to the wall sleeve and mounted to the facade with the provided stainless steel screws.

Step 3

Integrate external wall insulation channel in the facade insulation.

The integrated condensate drain allows horizontal mounting. This saves time and simplifies the adjustment of the surrounding insulation boards. Thermal bridges are avoided.



Step 4



Plaster facade and mount insulation channel grille.

Once the wall has been plastered, the protruding plaster frame can be removed and the insulation channel grille can be screwed on. Once the construction or renovation measures are complete, the unit can be inserted and connected electrically. The internal grille can then be attached.

PERFORMANCE



Performance

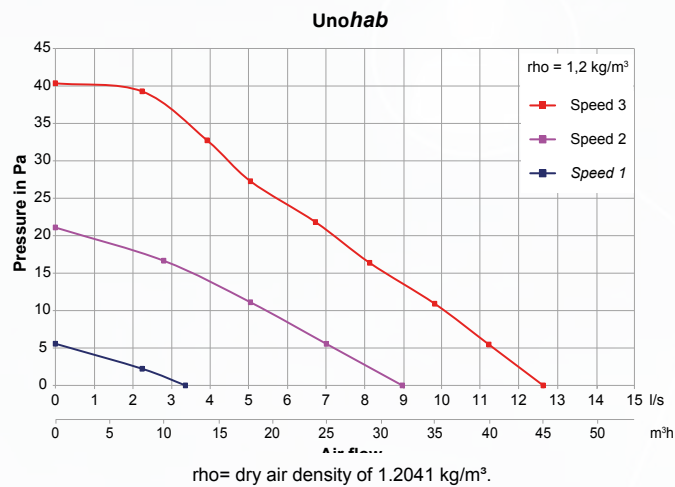

efficiency grade but can also reduce the carbon emissions and other pollutants coming from the outdoor air.

The UnoHab unit functions in three fan speed: low, average and boost. The fan performance can vary depending upon the running speed.

The performance graph shows maximum air flow against pressure at a dry air density of 1.2041 kg/m³. The maximum pressure induced by an UnoHab unit is 40 Pa when running at the highest speed (boost). As the lowest pressure is 5 Pa when running at the lowest speed. Depending upon the controller setting, commissioning and customers' requirements, the fan can run at an average level in between the highest and lowest speed giving the best performance.

The UnoHab unit performance is directly associated with its axial EC motor. Thanks to the EC fans, the demand of energy is lowered, and the motor has got a longer lifetime. The EC fans are economically used for maximum energy efficiency.

The ceramic heat recovery core is highly efficient, recovering up to 88% heat from the extracted air and transferring it to the supply air. The German design heat exchanger allows a large quantity of heat to be transferred due to its conductive and accumulative properties. Also, the ceramic heat exchanger is insulated with a heat insulating material (EPP=Expanded Polypropylene) layer so the heat recovered and stored into the core will not outflow.

The UnoHab system can form a whole-house system within each individual UnoHab unit, which will be perfectly coordinated and synchronized with each other.

UnoHab heat recovery system is specially designed to improve indoor air quality and reduce the risk of condensation and mould.

When running at the average speed, single room heat recovery units are more efficient than standard extract ventilation units. In addition, they can be much easier to install as the customer will have two options to choose from: through the wall installation or by using the external insulation vent kit through the window wall. By having a choice, the customer can customise the entire heat recovery system according to their requirements.

Recovering up to 88% of heat, the UnoHab unit is an innovative way of saving energy. Not only UnoHab does have a high

Technical data	UnoHab unit		
	1*	2*	3*
Fan speed	1*	2*	3*
Air flow supply/extract rate in Cross ventilation and Supply only mode [m³/h]	14	32	45
Sound pressure level LPA dB(A)	14	27	34
Sound insulation Dn,e,w	44 dB		
Power consumption [W]	1.6	2.8	4.5
Heat recovery efficiency	up to 88%		
Power supply	Input 230 V~ 50 / 60 Hz / Output 12 VDC		
Rated current [mA]	17	27	42
Protection class	IP20		
Unit power cable	NYM-O 2 x 1.5 mm²		
Controller power cable	NYM-O 2 x 1.5 mm²		
Fan power cable	J-Y (ST) Y 3x0.8 mm²		
Connection according to wiring diagram (see instructions manual)	SD-3 / SD-4		
Weight	2.8 kg		
Working range temperature	-12°C up to +40°C		

*Default fan speed

Unohab COMPLETE KITS



Unohab Cavity Wall Installation Kit



Part Number: 90001177

Kit for installation through the wall for one unit.
Consists of one Unohab unit and one cavity wall installation kit.

Unohab External Wall Insulation Vent Kit



Part Number: 90001178

Kit for installation in the window channel through the external wall insulation vent kit.
Consists of one Unohab unit and one external wall insulation vent kit.

Controller Flush Mounted Kit



Part Number: 90001179

Controller kit consists of one controller, one back box, one switching power supply for flush mounting and one extractor fan module to connect to the bathroom fan.

Controller DIN Rail Mounted Kit



Part Number: 90001180

Controller kit consists of one controller, one back box, one switching power supply for DIN rail mounting and one extractor fan module to connect to the bathroom fan.

COMPONENTS

Cavity Wall installation Kit



Cavity Wall Installation Kit 500 mm
Part number: 90000990

Consists of plastic wall sleeve (160 mm diameter) and white coated external vent.(dim. 272 x 230 x 50 mm (H x W x D) with bonded seal. EPP wedge included for attaching the wall sleeve with gradient for safe condensate drainage. (Core hole ≥ 162 with outward gradient) (Core hole ≥ 172 horizontal)

Cavity Wall Installation Kit 800 mm
Part Number: 90000991

Wall Sleeve



Wall Sleeve 500 mm
Part Number: 90001005

Diameter 160 mm made of plastic (length 500 mm). EPP wedge for attaching the wall sleeve with gradient for safe condensate drainage.

Wall Sleeve 800 mm
Part Number: 90001006

Diameter 160 mm made of plastic (length 800 mm). EPP wedge for attaching the wall sleeve with gradient for safe condensate drainage.

External Wall Insulation Vent Kit



External Wall Insulation Vent Kit
Stainless Steel Grille
Part Number: 90001002

Consists of plastic wall sleeve, 500 mm EPP soffit channel (fire protection class B1), stainless steel wall grille with integrated condensate drain and a seal.

External Wall Insulation Vent Kit
White Grille
Part Number: 90001165

Consists of plastic wall sleeve, 800 mm EPP soffit channel (fire protection class B1), white coated wall grille with integrated condensate drain and a seal.

External Wall Insulation Channel



Part Number: 90001008

Consists of 500 mm insulation wall sleeve and EPP soffit channel (Fire Protection According to EN 13501-1, Class B).

External white grille



Part Number: 90001007

White coated external grille for use on the external wall.

Part no: 90001004

White coated external deep grille for use on the external wall with a thickness of 250-300 mm.

Insulation channel grille

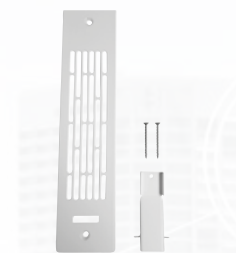

Insulation channel grille
stainless steel
Part number: 90001009

Insulation channel grille stainless steel with integrated condensate drain. Includes bonded seal.

Insulation channel grille white
Part number: 90001010

Insulation channel grille white with integrated condensate drain. Includes bonded seal.

COMPONENTS

Controller Kit Flush



Part Number: 90000994

Consists of *Unohab* controller and switching power supply (PSF) for installation in flush-mounted box.

Enables the connection of up to 6 units. In case of more than 6 units, an additional PSF is required. Maximum of 8 units per controller is possible.

Controller Kit DIN Rail

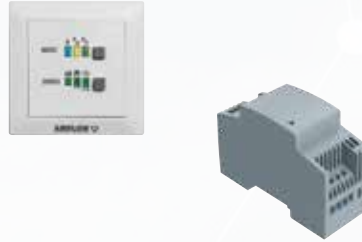

Part Number: 90000995

Consists of controller and switching power supply PSD for DIN rails (2 TE). Enables the connection of up to 4 units.

In case of more than 4 units, an additional PSF is required. Maximum of 8 units per controller is possible.

Unohab Unit



Part Number: 90000993

Consists of internal grille with filter, ceramic heat exchanger, flow straighteners, EC axial fan with protection grille, removal cord and EPP half shell base frame.

PSF (Power Supply Flush Mounted)



Part Number: 90000996

Switching power supply flush mounted used to extend the *Unohab* controller kit PSF from 6 to 8 units.

Input: 230V AC, 50 / 60 Hz,
Output: 12V DC / 1.9 A

Output voltage to SELV protection class III.

PSF (Power Supply DIN Rail Mounted)T

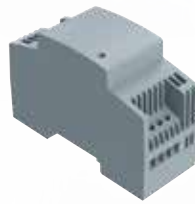

Part Number: 90000998

Switching power supply DIN rail mounted used to extend the *Unohab* controller kit PSD from 4 to 8 units.

Input: 230V AC, 50 / 60 Hz.

Output: 12V DC / 1.5 A for installation in the distribution box (2 TE). Output voltage to SELV protection class III.

Controller Case For Surface Mounting



Part Number: 90000999

White controller case for surface mounting.

ACCESSORIES

Brickwork Template Block



Brickwork Template Block 365 mm
Part Number: 90001000

New building template made of EPS, first protection class B1. Removes necessary core drilling.

Brickwork Template Block 490mm
Part no: 90001001

New building template made of EPS*, fire protection class B1. Removes necessary core drilling.

Humidity Sensor



Part Number: 9041570

Humidity sensor to connect to the controller's external contact.

Parallel connection with the Unohab Extractor fan module is not possible.

Dimensions:
76 x 76 x 34 mm (H x W x D)

Sound Insulation Element For Insulation Channel Installation



Part Number: 90001012

For use in soffit channel (max. 3 pcs. in full length channel). Manufactured from thermoset melamine foam and stainless steel. Fire protection class: B1. Improves sound insulation against external noise by 2 dB.

Dimensions:
94 x 180 x 32 mm (W x H x D).

Sound Insulation Element For Wall Sleeve Installation



Part Number: 90001011

For use in wall sleeve (max. 4 pcs. at 500 mm).

Manufactured from thermoset melamine foam. Fire protection class: B1. Improves sound insulation against external noise by 2 dB.

Dimensions:
Ø 156 mm; Depth: 50 mm.

Unohab G3 (ISO Coarse 50%) Filter Pack



Part Number: 90001014

Replacement air filter pack which consists of two G3 filters, ISO Coarse 50% according to ISO 16890.

Insect Grille



Part Number: 90001003

For installation with the external wall insulation vent kit. Stainless steel material.

Dimensions:
48 x 203 x 4 mm (W x H x D)

* Expanded Polystyrene

FIELD SUPPORT

Field support



Airflow do not view our customers just as a short term arrangement. We believe that by working together in partnership we can achieve better results in realising our shared objectives to deliver efficient, effective and reliable ventilation solutions so that you and your tenants are living in a healthy environment.

Our knowledgeable, trained technicians can provide support to ensure your ventilation projects run smoothly and where issues arise they can advise on the most suitable course of action to provide a successful outcome.

Airflow offers full field support across the UK, our after sales team can deal with any post sale needs and requirements. For any pre sale needs and requirements then our technical sales team can assist.



Contact us



Airflow Developments Limited

Tel: 01494 525252
e-mail: info@airflow.com

Customer Services

Tel: 01494 560800
e-mail: customer_services@airflow.com

Technical Support

Tel: 01494 560950
e-mail: technical_sales@airflow.com

Sales

Tel: 01494 560800
e-mail: sales@airflow.com

Airflow Developments Limited

Aidelle House, Lancaster Road,
Cressex Business Park,
High Wycombe, Buckinghamshire,
United Kingdom, HP12 3QP

airflow.com





UNITED KINGDOM (head office)

Airflow Developments Limited
Aidelle House, Lancaster Road
Cressex Business Park
High Wycombe, Bucks. HP12 3QP.

Tel: +44 (0) 1494 525252
Email: info@airflow.com
Web: airflow.com

GERMANY

Airflow Lufttechnik GmbH
Wolbersacker 16
53359 Rheinbach
Germany

Tel: +49 (0) 2226 92050
Email: info@airflow.de
Web: airflow.de

CZECH REPUBLIC

Airflow Lufttechnik - Praha
Hostynska 520
10800 Praha 10
Prague, Czech Republic

Tel: +42 (0) 2747 72230
Email: info@airflow.cz
Web: airflow.cz